



Package Contents / Packungsinhalt kontrollieren / Inhoud van de verpakking  
 検査包装内容物 / 検査包装内容 / パッケージ内容の確認

Vérifier le contenu de l'emballage / Verifi que o conteúdo da embalagem /  
 Compruebe el contenido del embalaje

Sprawdź zawartość pakietu / Проверка комплекта поставки / Obsah balení

Verifi care il contenuto della confezione / Ambalajın İçindekileri Kontrol Edin /  
 Paketinnehåll / Kassens indhold / Isi Kemasan مكونات الحزمة

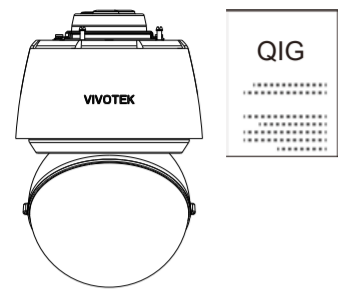

\* AM-220, AM-21P, AM-529, AM-101  
 are the selected accessories.

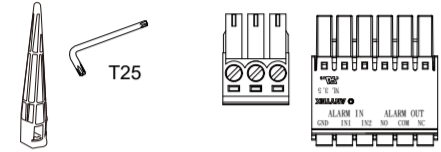

Hardware Installation / Hardwareinstallation / Hardware installeren

硬體架設 / 硬件安装 / ハードウェア・インストール

Installation du matériel / Instalacao de Hardware / Instalación del hardware

Instalacja sprzętu / Монтаж оборудования / Instalace hardwaru

Installazione hardware / Donanım Montajı / Installation av hårdvara

Installation af hardware / Pemasangan Perangkat Keras تركيب الأجهزة

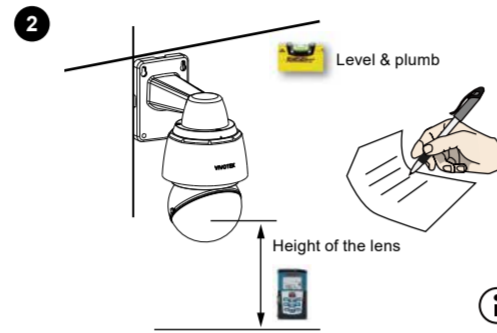
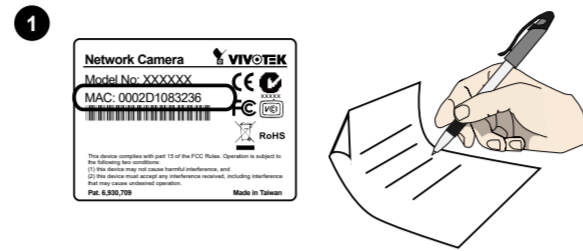

**i** When using VCA, installation height information is important.

## A-1. Remove EVA

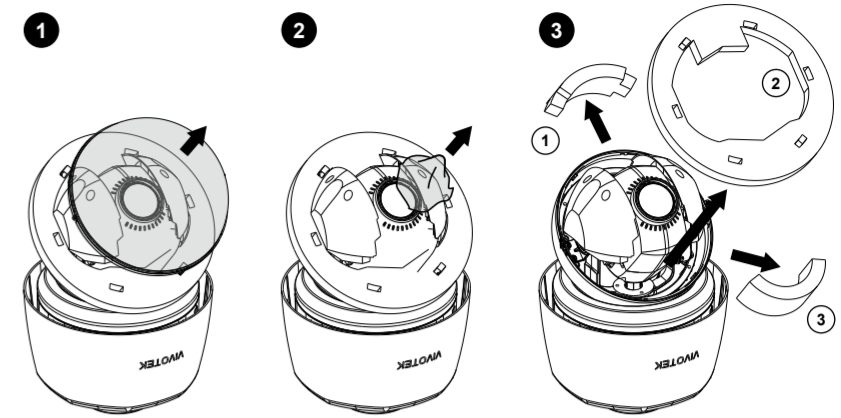

## A-2. Panel intrduce

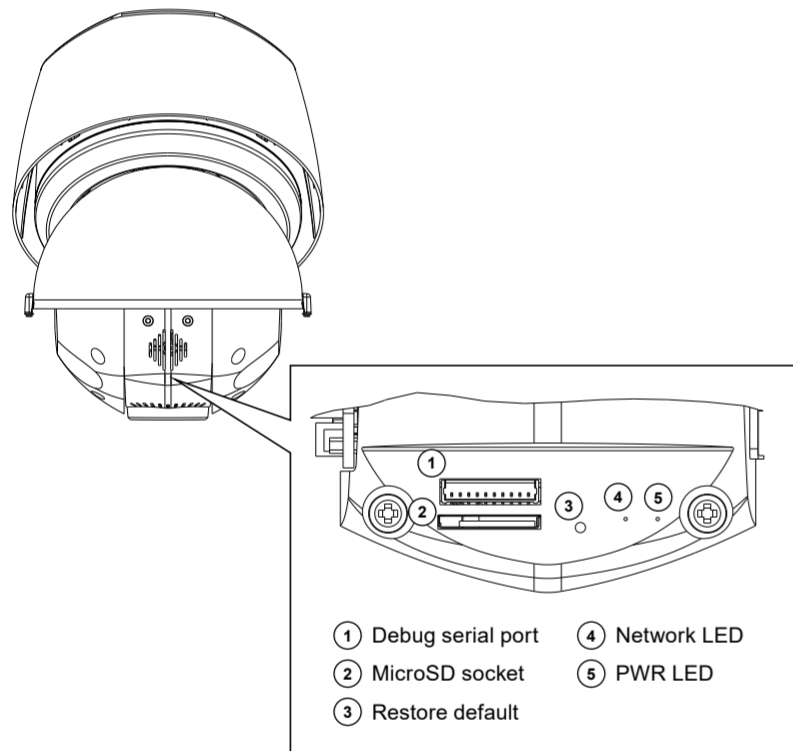

## A-3. Close bubble cap

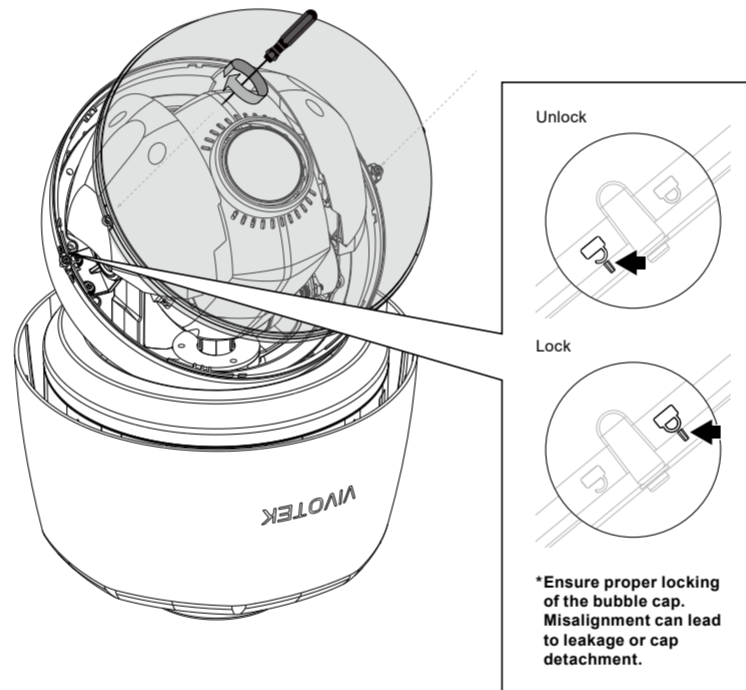

## B. Installation bracket

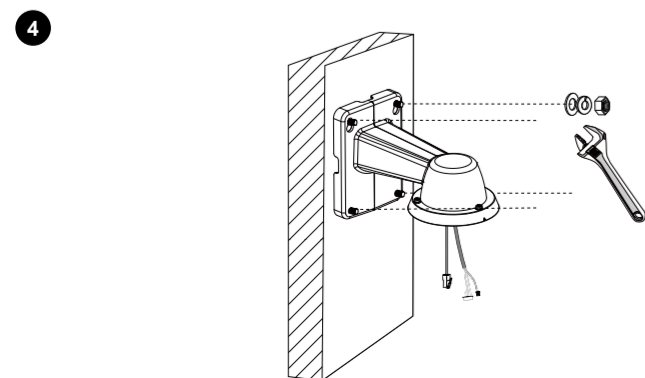
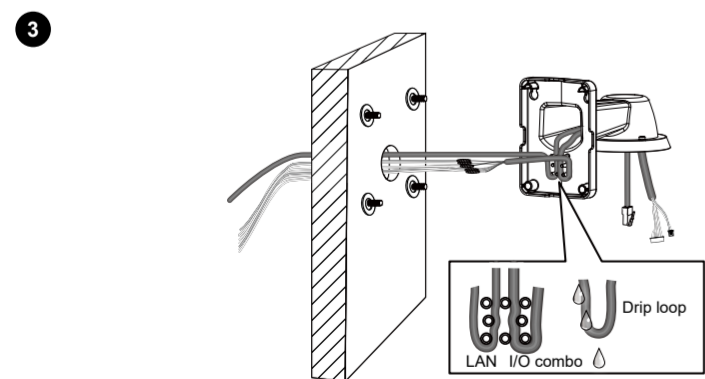
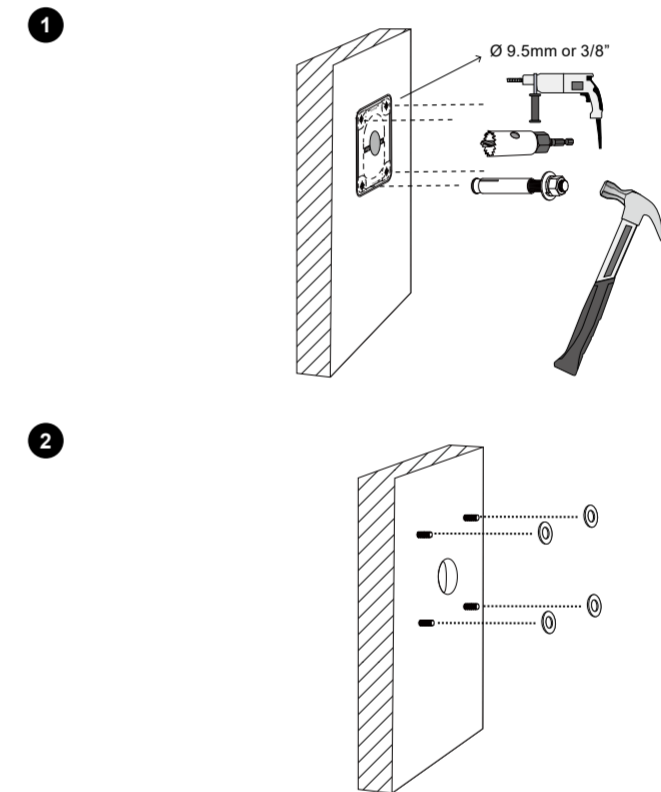

## C. Threading

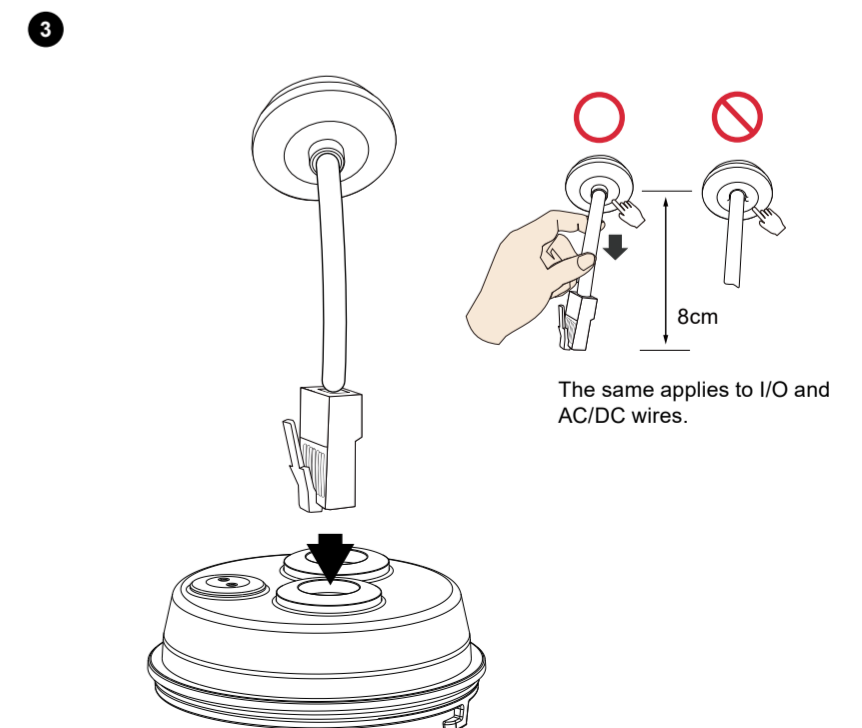
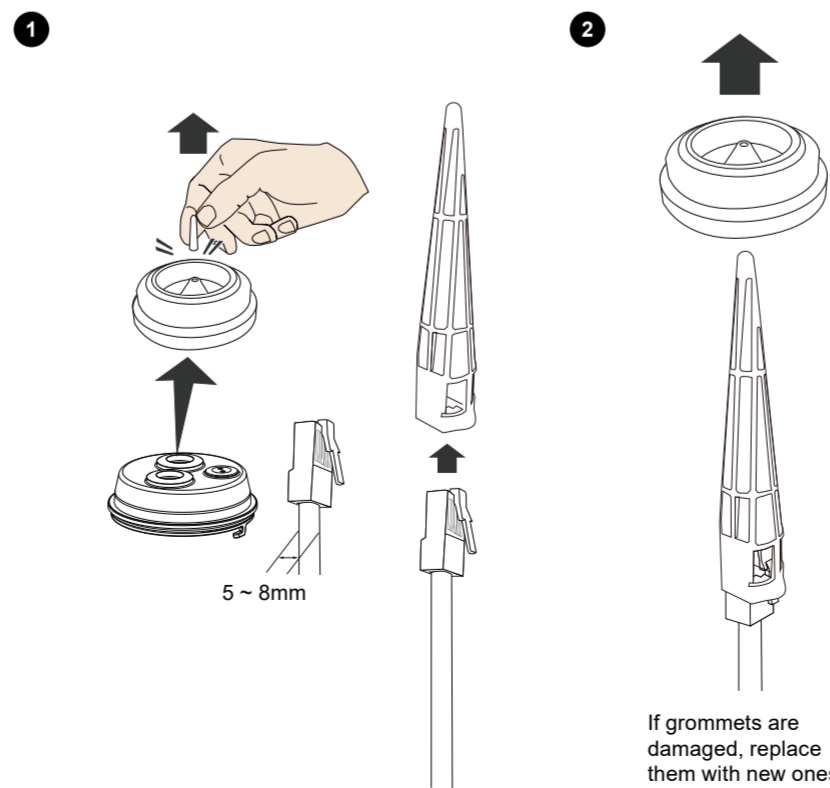

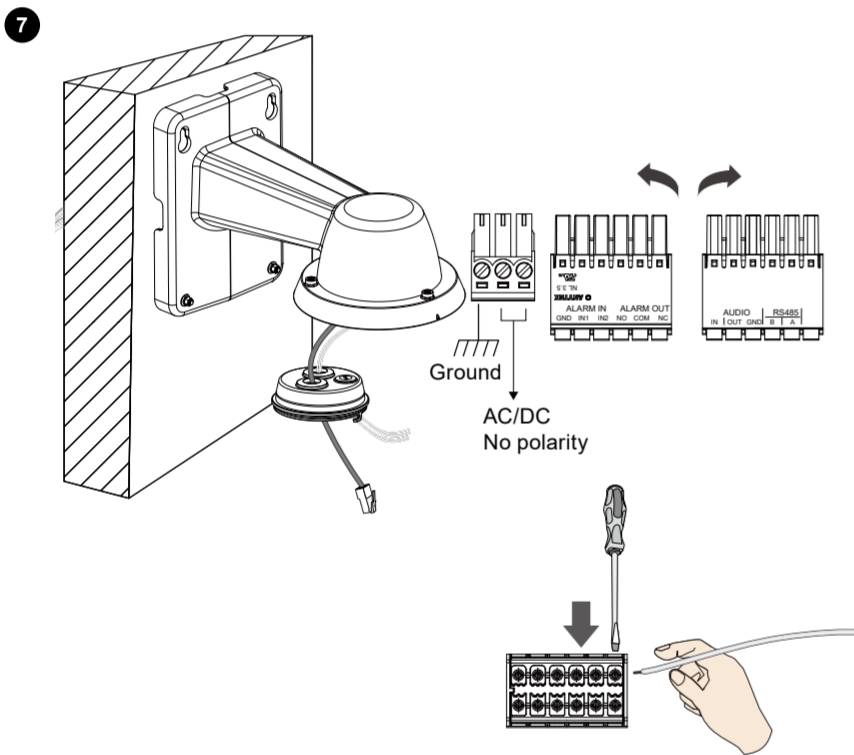
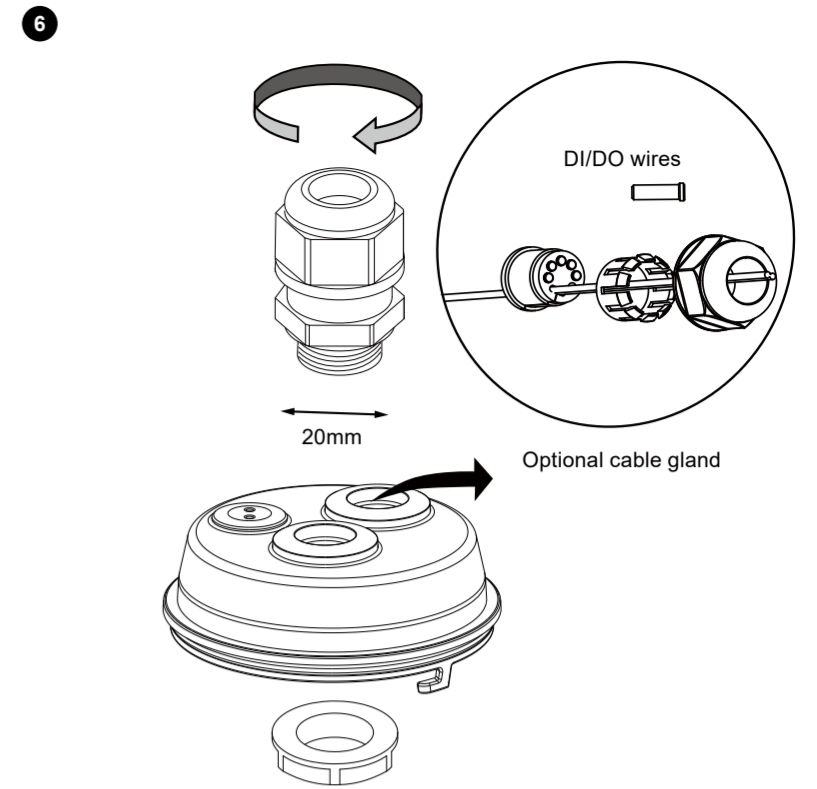
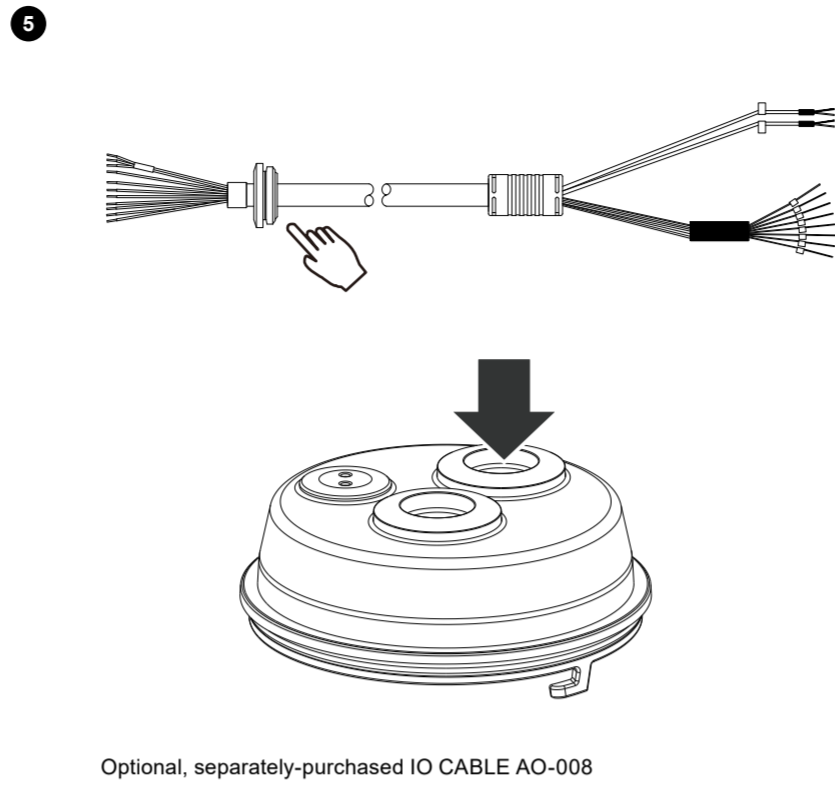
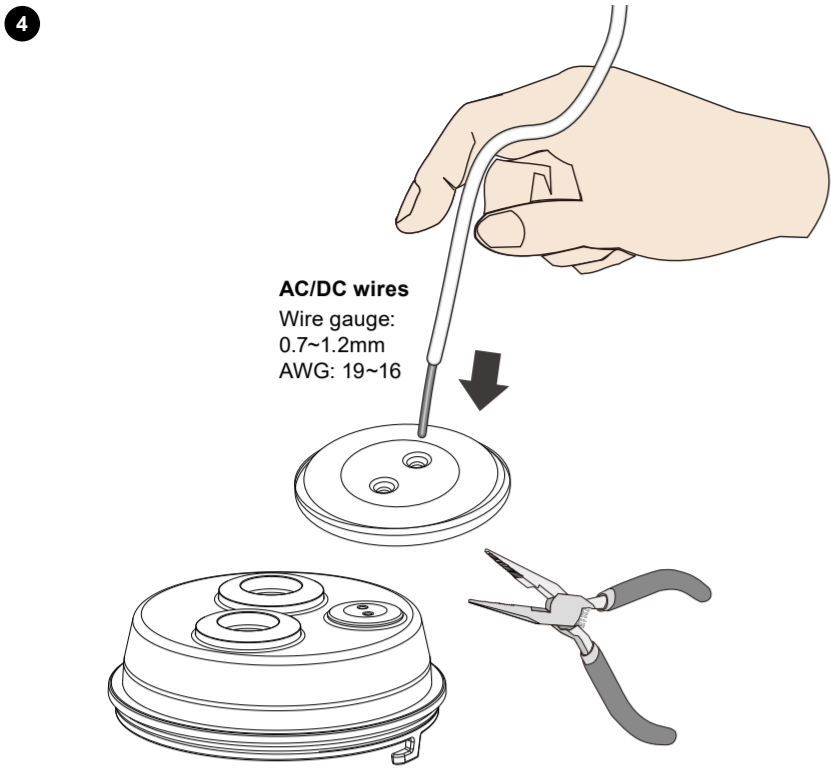

### D. Installation Camera

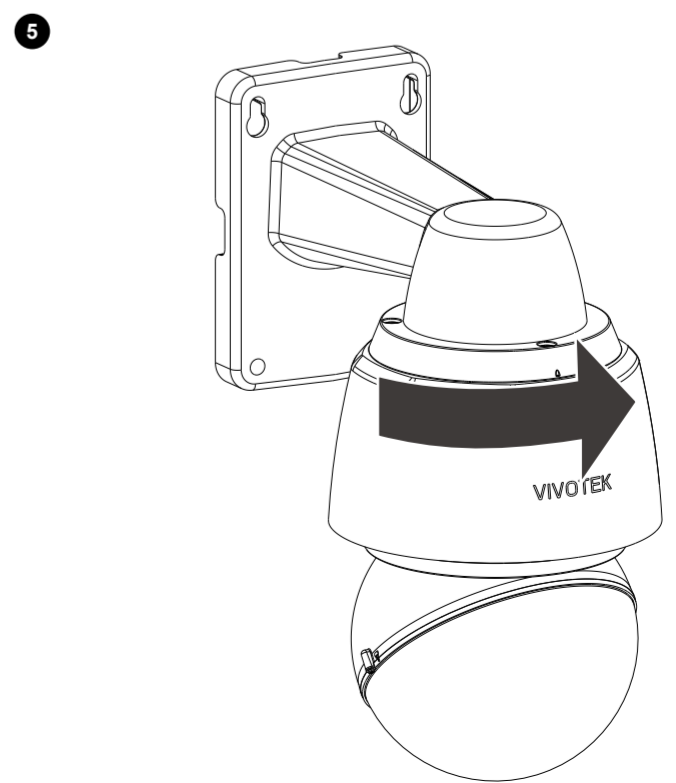
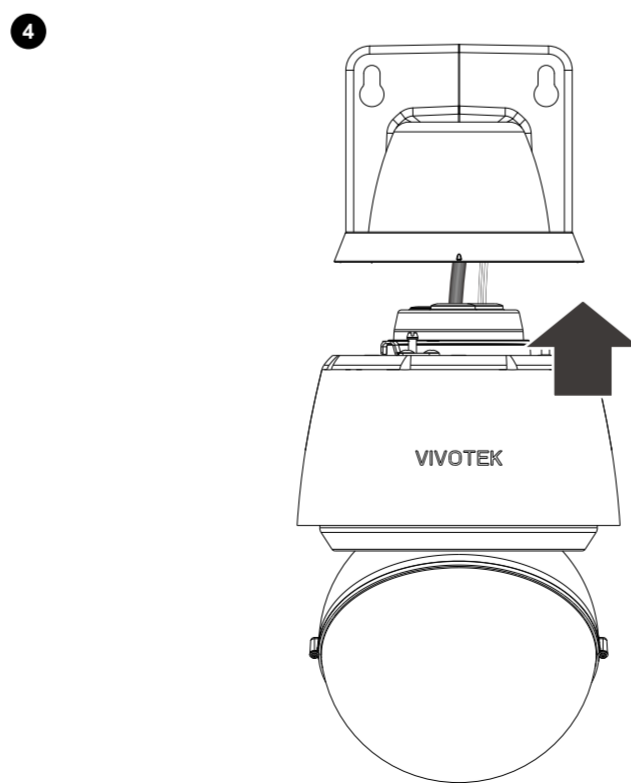
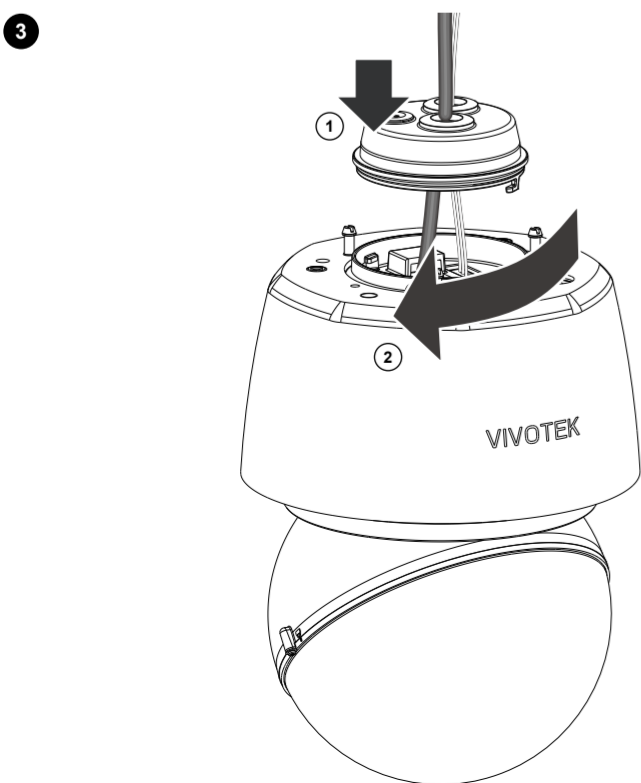
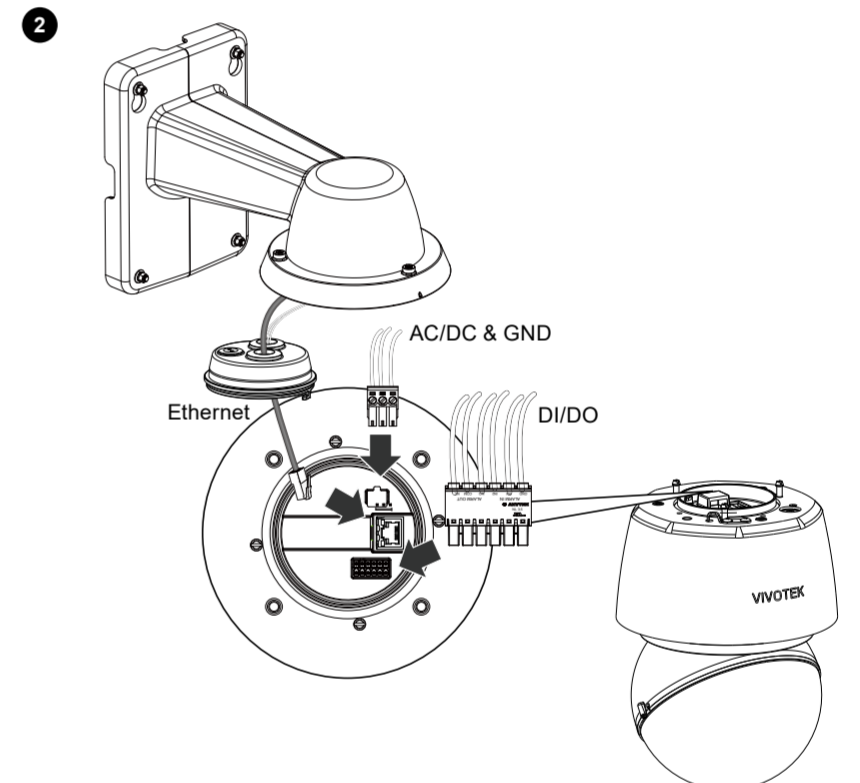
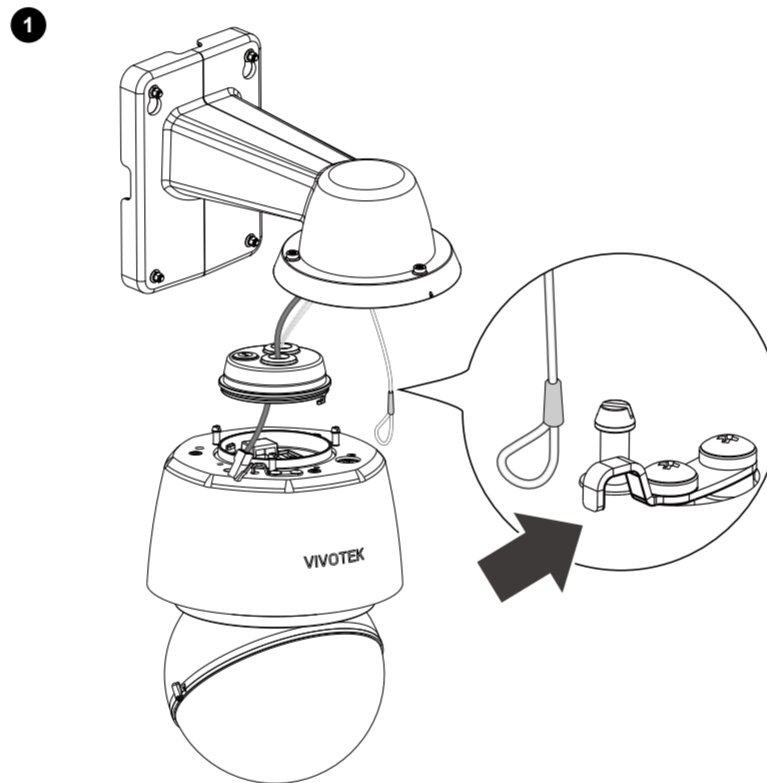

6

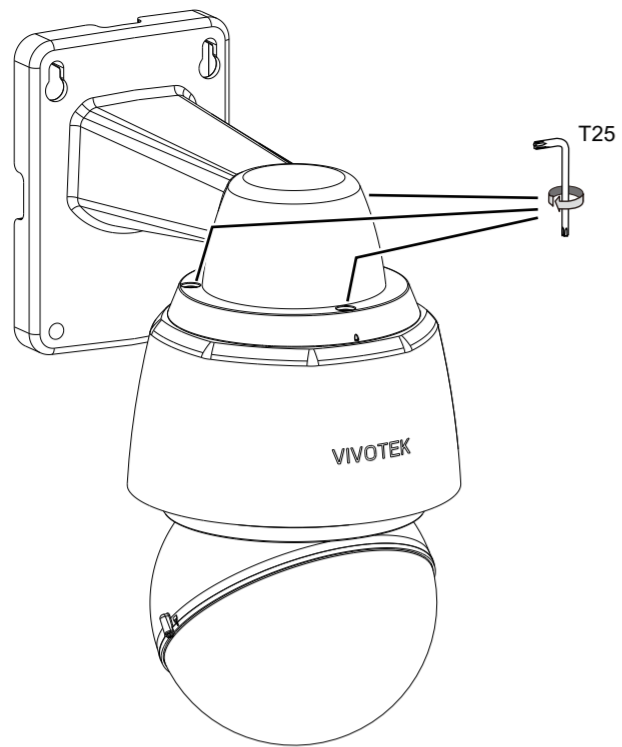

7

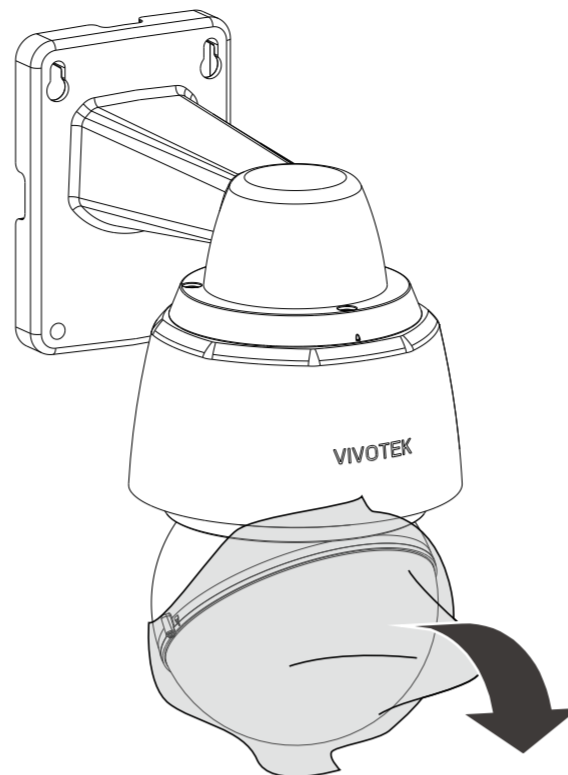

8

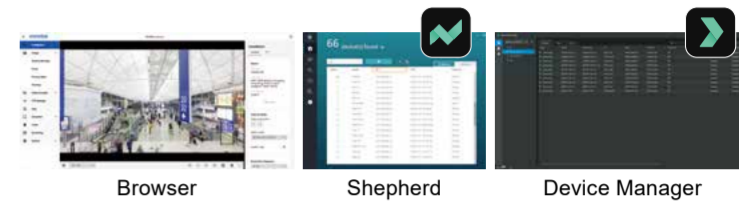
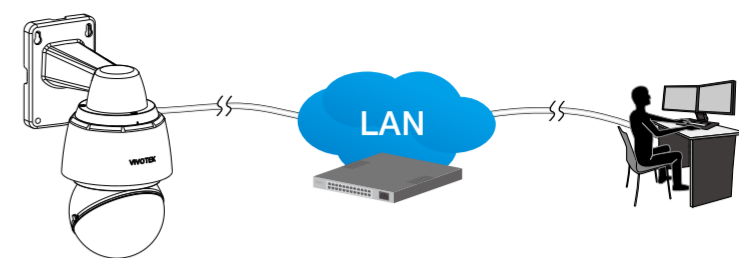

Please contact authorized distributors for warranty and RMA service.

**Warranty** [www.vivotek.com/support/warranty](http://www.vivotek.com/support/warranty)  
**RMA** [www.vivotek.com/support/rma](http://www.vivotek.com/support/rma)

**VIVOTEK**  
 A Delta Group Company

[www.vivotek.com](http://www.vivotek.com)

DESIGN AND SPECIFICATIONS ARE SUBJECT TO CHANGE WITHOUT NOTICE  
 Copyright © 2025 VIVOTEK INC. All rights reserved.